

TERRA TRIP

NEW v3 Series

Probes

The Terratrip requires one of the following probes:

WHEEL PROBE

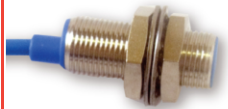

T005

This probe is fitted to 'look' at the bolts holding the brake disc to the hub on a non driven wheel

UNIVERSAL CABLE DRIVE PROBE



T006

This probe fits all cars with a mechanical speedometer cable

JAPANESE PROBE



T007

This probe is fitted between the gearbox and speedometer cable on many Japanese cars

DSI



T014

Dual Sensor Interface - For cars with electronic speed sensors, will also drive two tripmeters from one probe

Terratrip

202 v3 Rally Computer

T002



SIZE AND DIMENSIONS

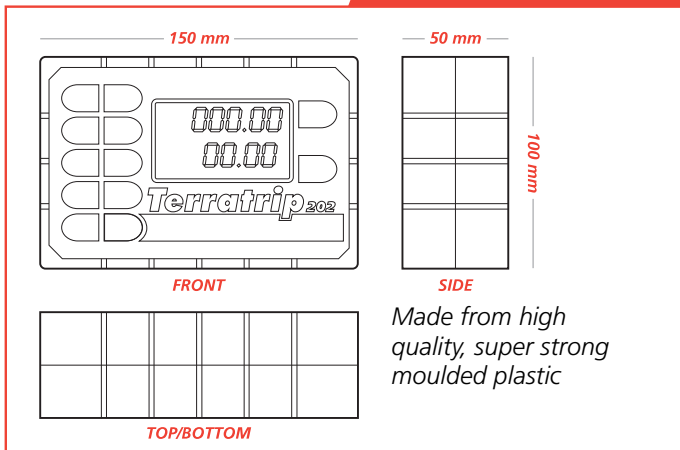

FEATURES

- Total distance display up to 999.99 and interval up to 99.99
- Speed indication
- Calibrate for miles or km
- 5 Digit Calibration
- Two calibration numbers
- Manually adjustable total distance display
- Count up and down facility
- Split (freeze) function
- Electronic memory back up
- Display back lighting
- Optional remote display for speed, interval distance or average speed. User fit
- Two probe inputs

Optional + Accessories

REMOTE ZEROING UNITS



T010

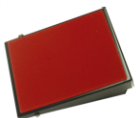

T008

Choose hand operated T010 or the T008 Foot operated unit

OPTIONAL REMOTE DISPLAY



T016

Optional remote display for speed, interval distance or average speed

BRACKET



T009

Dashboard and window mountable. With sun visor and suction cups

thoroughbred performance - when every second counts

Designed and Manufactured in the UK by:
Terratrip (UK) Ltd, Ship Farm, Horsley, Derby DE21 5BR, England
 Tel: +44 (0)1332 880468 Fax: +44 (0)1332 882640
 Email: info@terratrip.com Web: www.terratrip.com